

## Standard Installation

- 1.5 hour Static (B or C style; A or X frame): 119 (AB), 15S (CES), 17S (LD), 117 (AUI)  
 1.5 hour Static Thinline Frame: 119F (AB), 15SF (CES), 17SF (LD), 117F (AUI)  
 1.5 hour Dynamic (B or C style, A or X frame): D19 (AB), 15D (CES), 17D (LD), D17 (AUI)  
 1.5 hour Dynamic Thinline: D19F (AB), 15DF (CES), 17DF (LD), D17F (AUI)

### APPLICATION

This fire damper is intended to restrict the passage of flame. The standard installation requires that the damper is positioned so that the closed plane of the blades is within the fire rated masonry/concrete or metal or wood framed gypsum wallboard barrier.

This damper may be mounted in the vertical or horizontal position with the damper blades running horizontally. Airflow can be from either direction. When mounted in the vertical position, the damper can be mounted in a fire barrier constructed of masonry/concrete or metal or wood framed gypsum wallboard materials. When mounted in the horizontal positions, the damper can only be mounted in a fire barrier constructed of masonry/concrete materials with its locking teeth pointed down. Statically rated dampers are intended to close against no airflow. Dynamically rated dampers are intended to close against their rated airflow.

### INSTALLATION INSTRUCTIONS

1. **General:** The installation of the damper and all duct connections to the damper sleeve shall conform to NFPA-90A and the SMACNA Fire, Smoke and Radiation Damper Installation Guide. All duct connections shall also conform to UL555.
2. **Multiple Panel / Multiple Section Assembly:** Refer to page 6 for details.
3. **Sleeves:** Sleeves are required for the proper installation of fire rated dampers, but need not be factory mounted. Sleeves shall be the same gauge or heavier as the duct to which it is attached. Gauges shall conform to SMACNA or ASHRAE duct standards. A field supplied sleeve is attached to the damper frame with  $\frac{3}{16}$ " diameter steel rivets,  $\frac{1}{4}$ " diameter steel bolts, #10 steel sheet metal screws, or  $\frac{1}{2}$ " long welds. Fasteners shall be staggered on each side of the damper frame on 8" maximum centers and  $3\frac{1}{2}$ " maximum from each corner. A field supplied sleeve for a thin line damper is attached to the damper with minimum  $\frac{1}{2}$ " long stitch welds on both faces of the damper on 6" maximum centers with the first and last welds not exceeding 3" from one another. In any case, the sleeve shall not extend more than 6" beyond the fire barrier.
- 4a. **Expansion Clearance:** The opening in the wall for the fire rated damper shall be sized to provide expansion clearance between the sleeve and the opening. The minimum expansion clearance shall be the greater of  $\frac{1}{4}$ " or  $\frac{1}{8}$ " per foot of overall damper/sleeve width and height. The maximum expansion clearance shall not exceed  $\frac{1}{8}$ " per foot of overall damper/sleeve width and height plus 2".  
**Example:** For a damper with exact outside dimensions of 36"W x 48"H, the gap at the top plus the gap at the bottom must be between 0.5" and 2.5". The gap at the left side plus the gap at the right side must be between 0.375" and 2.375". The damper can be located anywhere in the opening and need not be centered.
- 4b. **Undercutting:** Width and Height dimensions apply to the frame size and do not include the outside sleeve thickness. If ordering with a heavy gauge sleeve, care must be taken to order the damper with additional undercuts to ensure the minimum required annular space is maintained.  
**Example:** For a damper ordered as 36" x 48" with no undercut and 10 ga. sleeves will have an approximate OD of 36 $\frac{1}{4}$ " x 48 $\frac{1}{4}$ ".
5. **Damper Orientation:** Dampers mounted vertically must be installed so the blades are at the top. The damper can be positioned so that airflow is from either direction. For dampers with springs, it is best to have access to the side of the damper opposite the leading blade edge. The pull ring option can be utilized when this is not practical. Dampers mounted horizontally must be installed so that the blade lock points are facing downward. The airflow can be from either direction. It is best to have access to the side at the damper opposite the leading blade edge (top side). The pull ring option can be utilized when this is not practical.
6. **Retaining Angle Attachment:** Perimeter retaining angles shall increase in size, proportionately, so there will be a minimum of 1" overlap on the wall, including at the corners. The angles shall be flush against the barrier. The leg attached to the damper can turn away from or into the opening. In metal frame construction, the angles can be mounted under or over the gypsum board. In wood frame construction, the angles must be mounted over the gypsum board. The perimeter mounting angles shall be fastened on all four sides and on both faces of the damper to the sleeve only, with  $\frac{3}{16}$ " diameter steel or stainless steel nuts and bolts or by tack welding with beads  $\frac{1}{2}$ "  $\pm$   $\frac{1}{4}$ " in length or with #10 steel or stainless steel sheet metal screws or  $\frac{3}{16}$ " steel or stainless steel pop rivets. (Note continued on page 2.)

(Instructions continued on Page 2.)

### SUPPLEMENTAL INSTALLATION INSTRUCTIONS / SUBMITTAL DATA

- |   |   |
|---|---|
| Standard submittal – SD-1.5CFD                  | Corrugated decking – SI-DECKING                             |
| Shaft wall openings – II-U438                   | Sleeve extensions – SI-SLVEXT                               |
| Grille transfer applications – SI-GTFD          | One-side retaining angle installations – SI-FSOS            |
| Grille access applications – SI-GAFD            | Retaining angle or flange under gypsum wallboard – SI-FUGWB |
| Out-of-barrier applications – SI-OOWFD          | Flanged duct connections – SI-ULFDC                         |
| Out-of-barrier C-style applications – SI-OOWCFD | Caulking – SI-CAULK   |
| Fire resistance duct assembly – SI-FAPN         |   |



## INSTALLATION INSTRUCTIONS

(Continued)

**6. Retaining Angle Attachment (Cont.):** All connections shall be spaced on 8" maximum centers and 3" maximum from each corner (a minimum of 2 fasteners are required per side). For perimeter angle mounting on one side of the fire barrier only, reference Installation Instruction II-FSOS. Perimeter retaining angles shall be a minimum of 1½" x ¾" x 16-GA steel. Corners of angles are not welded together for dampers with width or height dimensions exceeding 24". For dampers 24"W x 24"H or smaller, the corners of the perimeter mounting angles can be welded. Some local codes may not allow welded corners. Attachment of these angles must not restrict operation of the damper. Perimeter retaining angles and their mounting fasteners are not typically supplied with the damper.

**7. Caulking:** Caulk that is exposed to the airstream (ie on the inside of the damper sleeve) shall be one of the following: Dow Corning RTV732, Silco Sil-Bond RTV 4500, General Electric IS808, or Novagard RTV300. Breakaway flange caulking shall be Design Polymeric's DP1010 or Precision's PA2084T. Caulk that is not exposed to the airstream (ie on the outside of the damper sleeve) can be of any type that is certified (UL Classified) to have a flame/smoke developed index of 25/50 or less (re: UL723) and is approved by the local authority having jurisdiction. Caulking is allowed on any external/exposed portions of the damper sleeve, but is not permitted to be in the annular space between the fire barrier and the damper sleeve.

**8. Duct Connections:** All connecting ducts shall not be continuous, but shall terminate at the fire damper sleeve. Duct connections not listed as breakaways shall be considered rigid. For rigid type duct connections, the sleeve shall be a minimum of 16-GA on dampers not exceeding 36" wide or 24" high or 24" diameter and 14-GA on larger units. Maximum sleeve thickness shall not exceed 10-GA galvanized steel. Dampers supplied with thinner sleeves require a breakaway connection. The following breakaway duct-to-sleeve connections may be used: Plain "S" Slip, Double "S" Slip, Inside Slip, Hemmed "S" Slip, Standing "S" Slip, Standing "S" Slip (Bar Reinforced), Standing "S" Slip (Angle Reinforced), and Standing "S" Slip (Alternate Bar). Breakaway joints shall have no more than two No. 10 sheet metal screws on each side and on the bottom. The screws shall penetrate both sides of the slip pocket. When a breakaway joint is used along the top and bottom duct connection, a flat drive slip no longer than 20 inches is permitted on the two sides.

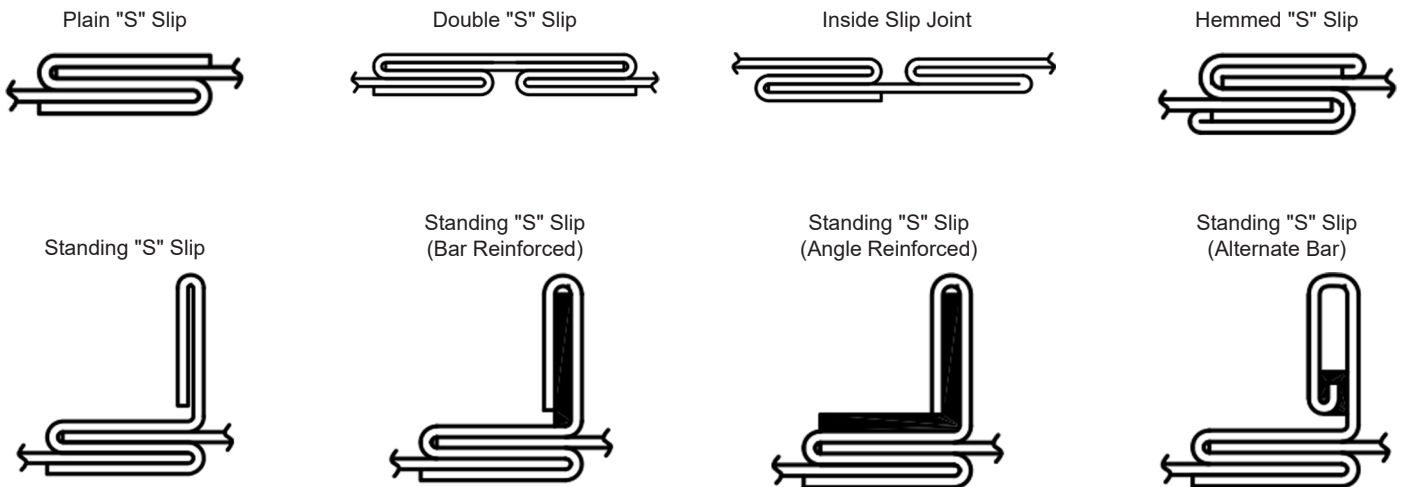

The factory supplied round/oval transition provides the breakaway connection if the following conditions are satisfied.

1. Round duct diameter is no larger than 36".
2. Oval duct size is no larger than 71"W x 30"H.
3. Duct gauges conform to the SMACNA or ASHRAE standard.
4. An oval duct or round duct less than or equal to 24" is attached to the transition collar with #8 sheet metal screws (a minimum of 4 fasteners per connection). A round duct diameter greater than 24" is attached to the transition collar with #10 sheet metal screws (a minimum of 5 fasteners per connection).

Dampers with round/oval transitions that fall outside of these restrictions must use a 4" wide drawband connection as shown in the SMACNA Fire, Smoke, and Radiation Damper Installation Guide.

**9. Maintenance:** Dampers shall be maintained at intervals as stated in NFPA 90A and 92A. Local codes or building conditions may require more frequent inspections and maintenance. A duct access door, provided by others, is to be located on one side of each damper for periodic inspection and maintenance. The access doors shall be properly sized so as to allow adequate access to dampers. In cases of small and/or transitioned dampers, removable cap/collar transitions or removable duct may be required to permit access where large enough access doors can not be fitted.



## MULTIPLE PANEL SIZE LIMITATIONS

Vertical and Horizontal Dampers for Static Closure

Orientation Assembly	Horizontal Mount		Vertical Mount	
	Max Panel	Max Assy	Max Panel	Max Assy
119A, 17SA, 15SA, 117A	48"W x 48"H	102"W x 48"H	60"W x 60"H	120"W x 120"H
119F, 17SF, 15SF, 117F	-	-	40"W x 40"H	-
119B, 17SB, 15SB, 117B	48"W x 42"H duct (48"W x 48"H frame)	102"W x 42"H duct (102"W x 48"H frame)	60"W x 53"H duct (60"W x 60"H frame)	120"W x 113"H duct (120"W x 120"H frame)
119C, 17SC, 15SC, 117C	46"W x 41"H duct (48"W x 48"H frame)	100"W x 41"H duct (102"W x 48"H frame)	58"W x 52"H (60"W x 60"H frame)	118"W x 112"H (120"W x 120"H frame)
119X, 17SAX, 15SAX, 117AX	48"W x 48"H	-	60"W x 60"H	-
119XB, 17SBX, 15SBX, 117BX	48"W x 42"H duct (48"W x 48"H frame)	-	60"W x 53"H duct (60"W x 60"H frame)	-
119XC, 17SCX, 15SCX, 117CX	46"W x 41"H duct (48"W x 48"H frame)	-	58"W x 52"H (60"W x 60"H frame)	-

Horizontal Dampers for Dynamic Closure

Orientation Assembly	Horizontal, 2000 fpm, 4" w.g.		Horizontal, 2000 fpm, 8" w.g.		Horizontal, 4000 fpm, 4" w.g.	
	Max Panel	Max Assy	Max Panel	Max Assy	Max Panel	Max Assy
D19A, 17DA, 15DA, D17A	24"W x 24"H or 18"W x 36"H	72"W x 36"H	18"W x 36"H	36"W x 36"H	18"W x 36"H	36"W x 36"H
D19B, 17DB, 15DB, D17B	24"W x 20"H (duct) (24"W x 24"H frame) or 18"W x 31"H (duct) (18"W x 36"H frame)	72"W x 31"H (duct) (72"W x 36"H frame)	18"W x 31"H (duct) (18"W x 36"H frame)	36"W x 31"H (duct) (36"W x 36"H frame)	18"W x 31"H (duct) (18"W x 36"H frame)	36"W x 31"H (duct) (36"W x 36"H frame)
D19C, 17DC, 15DC, D17C	22"W x 19"H (duct) (24"W x 23"H frame) or 16"W x 30"H (duct) (18"W x 36"H frame)	70"W x 30"H (duct) (72"W x 36"H frame)	16"W x 30"H (duct) (18"W x 36"H frame)	34"W x 30"H (duct) (36"W x 36"H frame)	16"W x 30"H (duct) (18"W x 36"H frame)	34"W x 30"H (duct) (36"W x 36"H frame)
D19AX, 17DAX, 15DAX, D17AX	24"W x 24"H	-	18"W x 36"H	-	18"W x 36"H	-
D19BX, 17DBX, 15DBX, D17BX	24"W x 20"H duct (24"W x 24"H frame)	-	18"W x 31"H (duct) (18"W x 36"H frame)	-	18"W x 31"H (duct) (18"W x 36"H frame)	-
D19CX, 17DCX, 15DCX, D17CX	22"W x 19"H duct (24"W x 23"H frame)	-	16"W x 30"H (duct) (18"W x 36"H frame)	-	16"W x 30"H (duct) (18"W x 36"H frame)	-



# INSTALLATION INSTRUCTION

## MULTIPLE PANEL SIZE LIMITATIONS (Cont.)

### Vertical Dampers for Dynamic Closure

Orientation	Vertical, 2000 fpm, 4" w.g.		Vertical, 2000 fpm, 8" w.g.	
	Assembly	Max Panel	Max Assy	Max Panel
D19A, 17DA, 15DA, D17A	36"W x 36"H	72"W x 48"H, 48"W x 72"H, 120"W x 24"H, or 24"W x 120"H	24"W x 24"H	72"W x 48"H, 48"W x 72"H, 120"W x 24"H, or 24"W x 120"H
D19F, 17DF, 15DF, D17F	24"Wx24"H	-	-	-
D19B, 17DB, 15DB, D17B	36"W x 31"H duct (36"W x 36"H frame)	72"W x 44"H duct (72"W x 48"H frame), 48"W x 69"H duct (48"W x 72"H frame), 120"W x 20"H duct (120"W x 24"H frame), or 24"W x 116"H duct (24"W x 120"H frame)	24"W x 20"H duct (24"W x 24"H frame)	72"W x 45"H duct (72"W x 48"H frame), 48"W x 69"H duct (48"W x 72"H frame), 120"W x 20"H duct (120"W x 24"H frame), or 24"W x 116"H duct (24"W x 120"H frame)
D19C, 17DC, 15DC, D17C	34"W x 30"H duct (36"W x 36"H frame)	70"W x 44"H duct (72"W x 48"H frame) 46"W x 68"H duct (48"W x 72"H frame), 118"W x 19"H duct (120"W x 24"H frame), or 22"W x 115"H duct (24"W x 120"H frame)	22"W x 19"H duct (24"W x 24"H frame)	70"W x 44"H duct (72"W x 48"H frame) 46"W x 68"H duct (48"W x 72"H frame), 118"W x 19"H duct (120"W x 24"H frame), or 22"W x 115"H duct (24"W x 120"H frame)
D19AX, 17DAX, 15DAX, D17AX	36"W x 36"H	-	24"W x 24"H	-
D19BX, 17DBX, 15DBX, D17BX	36"W x 31"H duct (36"W x 36"H frame)	-	24"W x 20"H duct (24"W x 24"H frame)	-
D19CX, 17DCX, 15DCX, D17CX	34"W x 30"H duct (36"W x 36"H frame)	-	22"W x 19"H duct (24"W x 24"H frame)	-

Orientation	Vertical, 4000 fpm, 4" w.g.	Vertical, 4000 fpm, 8" w.g.
	Assembly	Max Panel
D19A, 17DA, 15DA, D17A	18"W x 36"H or 24"W x 24"H	24"W x 24"H
D19F, 17DF, 15DF, D17F	-	-
D19B, 17DB, 15DB, D17B	18"W x 31"H (18"W x 36"H frame) or 24"W x 20"H (24"W x 25"H frame)	24"W x 20"H (24"W x 24"H frame)
D19C, 17DC, 15DC, D17C	16"W x 30"H (18"W x 36"H frame) or 22"W x 19"H (24"W x 24"H frame)	22"W x 19"H (24"W x 24"H frame)
D19AX, 17DAX, 15DAX, D17AX	18"W x 36"H or 24"W x 24"H	24"W x 24"H
D19BX, 17DBX, 15DBX, D17BX	18"W x 31"H (18"W x 36"H frame) or 24"W x 20"H (24"W x 25"H frame)	24"W x 20"H (24"W x 24"H frame)
D19CX, 17DCX, 15DCX, D17CX	16"W x 30"H (18"W x 36"H frame) or 22"W x 19"H (24"W x 24"H frame)	22"W x 19"H (24"W x 24"H frame)



In the interest of product development, Mestek CDLG reserves the right to make changes without notice.  
450 Riverside Rd • Wyalusing PA, 18853 • Phone 570-746-1888 • Fax 570-746-9286

# INSTALLATION INSTRUCTION

## STANDARD MOUNTING DETAILS

Type A, Vertical

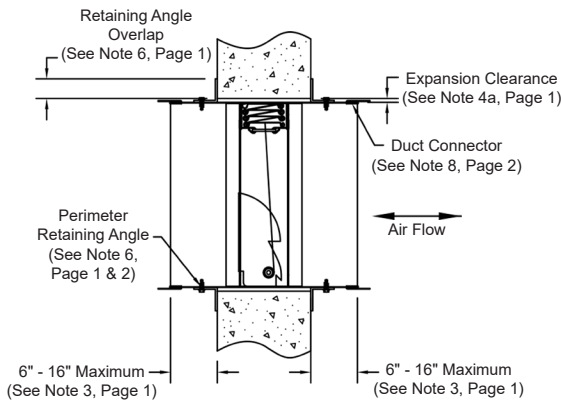

Type B, Vertical

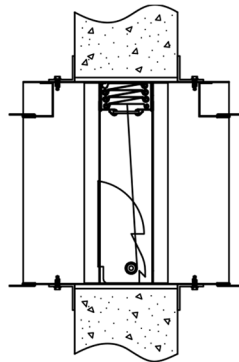

Type C, Vertical

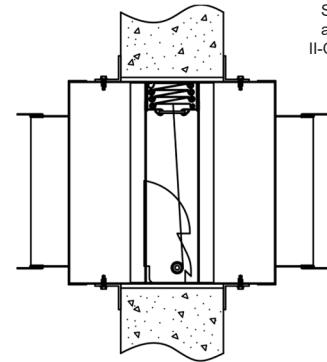

See also alternate II-OOWCFD

Type A, Horizontal

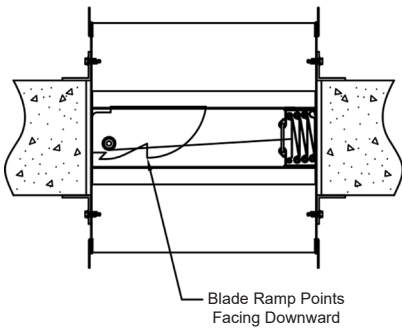

Type B, Factory Sleeve, Horizontal

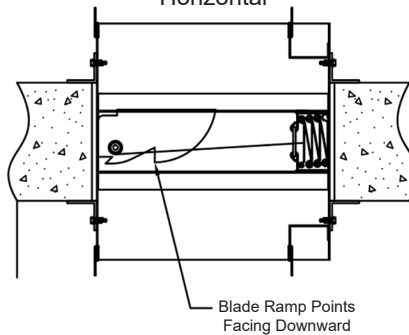

Type C, Factory Sleeve, Horizontal

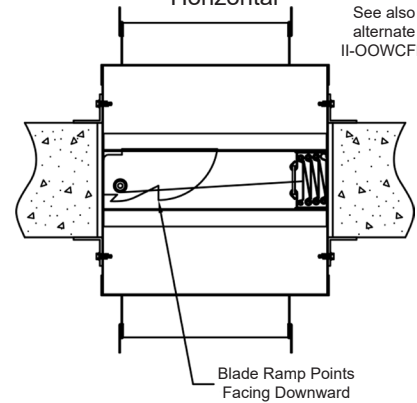

See also alternate II-OOWCFD

Type B, Field Sleeve, Vertical

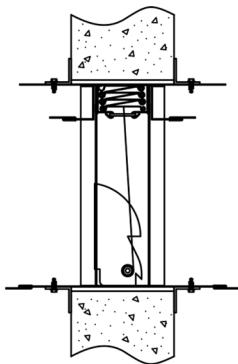

Alternative Type B, Field Sleeve, Vertical

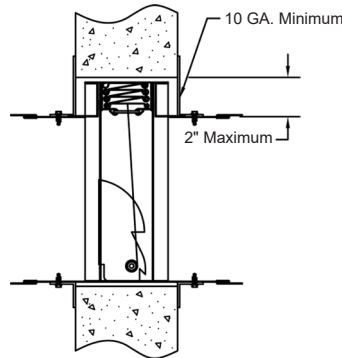

Type C, Field Sleeve, Vertical

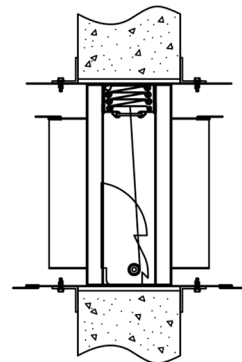

Type B, Field Sleeve, Horizontal

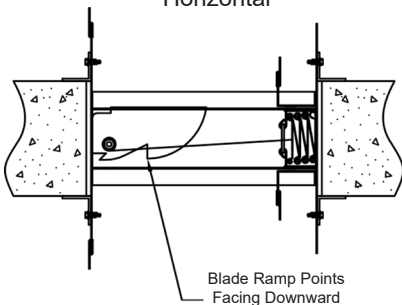

Alternative Type B, Field Sleeve, Horizontal

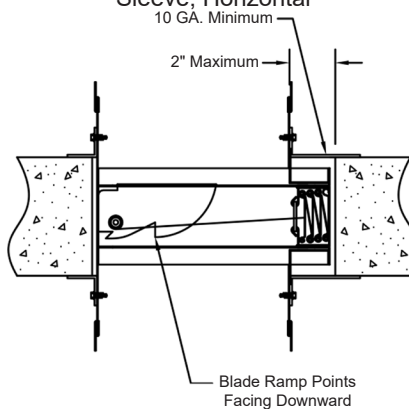

Type C, Field Sleeve, Horizontal

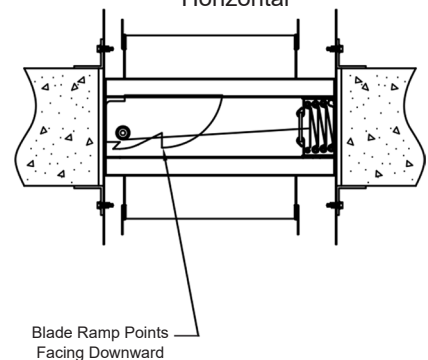

Blade Ramp Points Facing Downward



## MULTIPLE PANEL / MULTIPLE SECTION INSTALLATION DETAILS

1. Damper assemblies ordered without factory mounted sleeves typically ship in individual panels to be field assembled.
2. Damper assemblies ordered with factory mounted sleeves ship assembled. Due to shipping limitations large damper assemblies may require more than one ship section. If more than one ship section is required, each ship section will be individually sleeved.
3. Mullion stiffeners are required per the illustrations below. The details shown are typical for all mullions in the same direction for that mounting orientation. For ship loose panels, mullion stiffeners are typically not provided by the factory. For single ship section sleeved dampers, mullion stiffeners will ship assembled as required. For multiple ship section sleeved dampers, the mullion stiffeners will ship assembled as required within each sleeved section. Mullion stiffeners are not required between the sleeved sections.
4. For vertical installations where the wall/floor opening is larger than the approved maximum assembly size, the approved mullion (illustrated on pages 8 and 9) must separate the large opening into smaller openings. This is approved for static systems only. For installations not covered by this method, the Local Authority Having Jurisdiction must approve a mullion to separate the large opening into smaller openings.
5. Mullion details specified are based on the fire ratings qualification tests. The user is responsible for additional structural supports of multiple section dampers when required by elevated air pressure differential in the closed position and in some cases seismic loading.

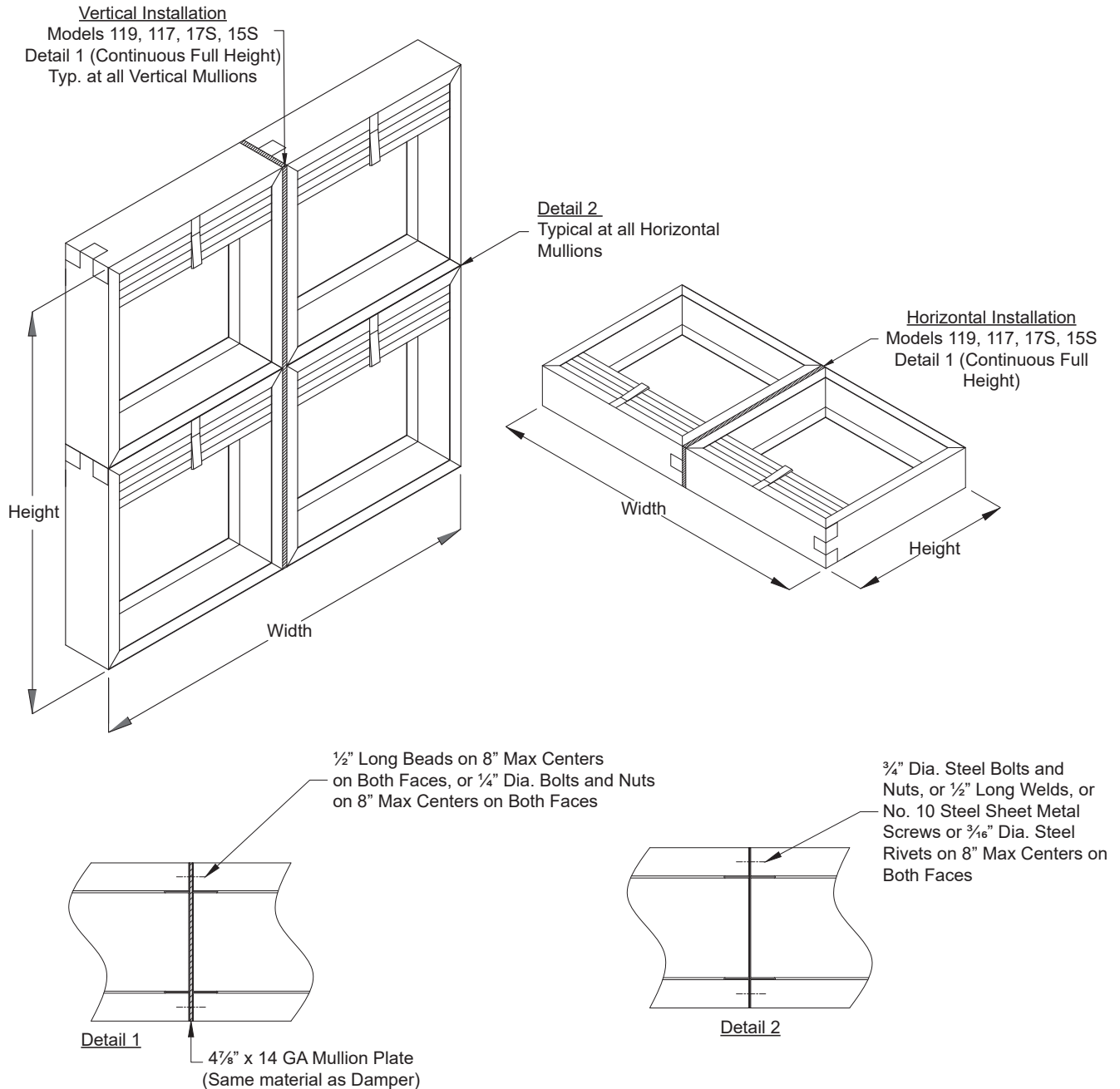



## FRAMING DETAILS (METAL OR WOOD, 1 HOUR OR 2 HOUR RATED BARRIERS)

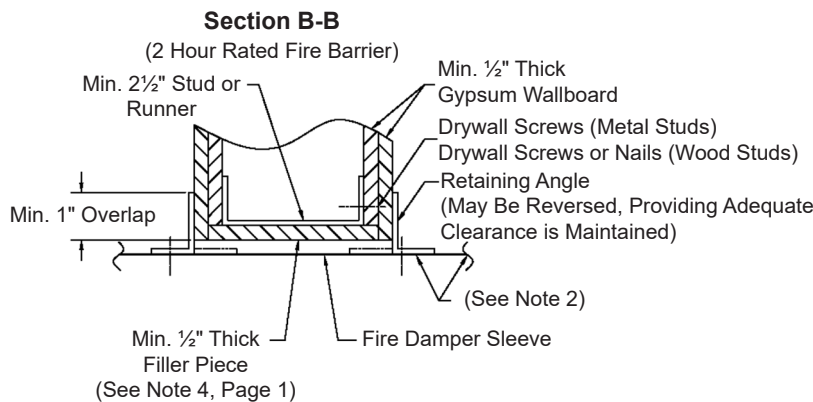
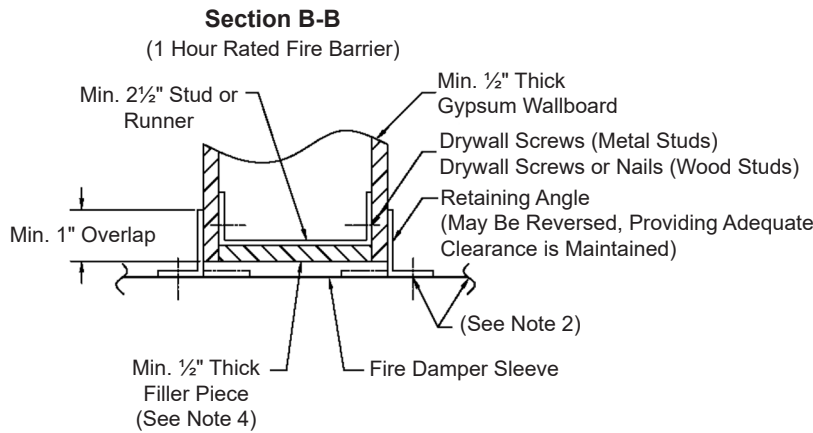
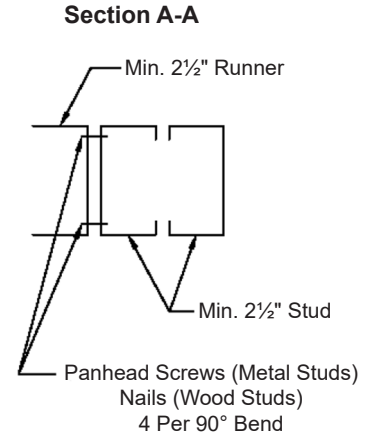
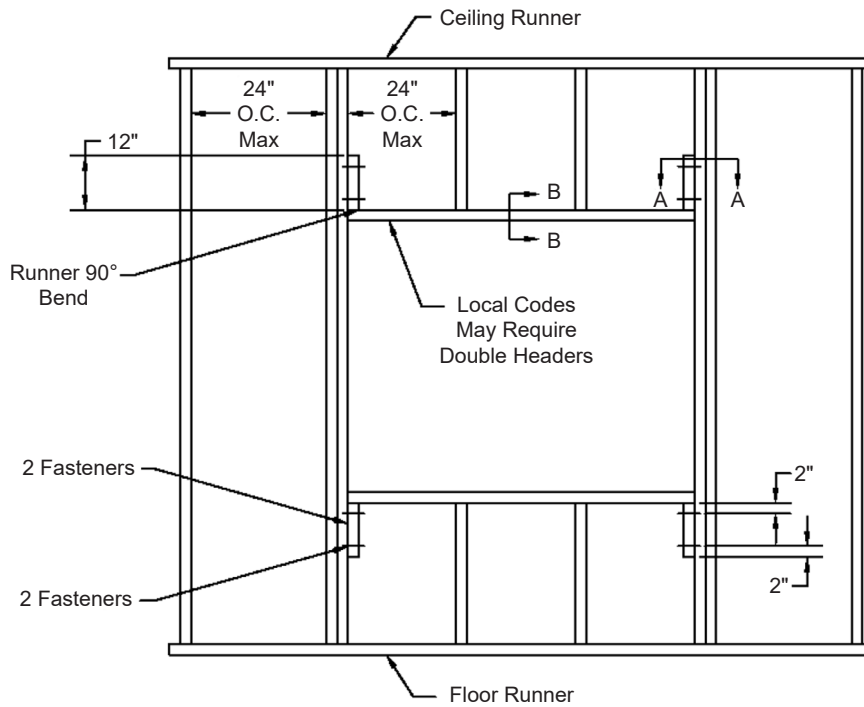

**NOTES:**

1. These illustrated partition designs have successfully been tested in conjunction with 1 1/2 hour classified fire dampers, for additional designs, reference Underwriters Laboratories, Inc. Fire Resistance Directory. Specific framing requirements of openings may vary with the Local Authority that has jurisdiction. Specific framing requirements should be provided in the architectural and structural drawings.
2. Reference the damper's installation instructions regarding the approved method of attaching the damper to the sleeve, attaching the retaining angles to the sleeve, required expansion clearances, sleeve gauge, etc. Type of framing does not affect the stated required expansion clearance.
3. Gypsum panels surrounding the opening are to be fastened to all stud and runner flanges, 12" O.C. maximum.
4. When wooden studs are used, filler pieces must be installed around the entire opening. Filler pieces are optional when metal studs are used (consult local codes to determine if filler pieces are required). Filler pieces are to be double screwed (or nailed to wooden studs) on 12" max. centers to the web of runners and studs.
5. Double jamb studding shown and required when opening width or length exceeds 36". Single jamb studding acceptable for openings 36"W x 36"H and smaller.



# INSTALLATION INSTRUCTION

## INSTALLATION DETAILS FOR OVERSIZED WALL OPENINGS

### Mullion Installation Instructions for Fire Dampers

(Static Curtain Damper Models Only)

#### APPLICATION

These fabricated galvanized steel mullions are intended to subdivide a large vertical wall opening into smaller openings. These smaller openings are not to exceed the maximum size restrictions of the UL Classified 1½ hour galvanized steel fire damper assembly.

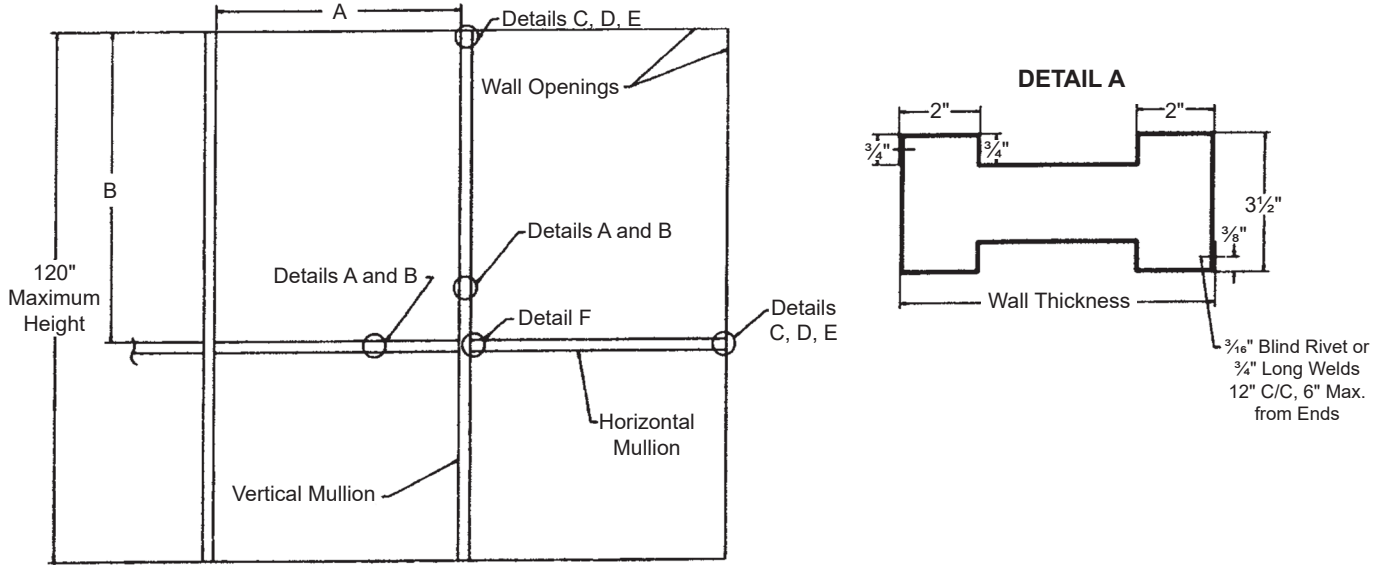

'A' and 'B' opening sizes are not to exceed the damper's approved maximum multiple assembly size. Vertical, horizontal, or vertical and horizontal mullions can be used, depending on the opening size.

#### CONDITIONS & RESTRICTIONS

- Fabricated from galvanized steel with a nominal yield strength of 42,000 PSI.
- Intended for use in concrete block or poured walls only with a minimum wall thickness of 7" and a maximum wall thickness of 12".
- To permit proper embedding of anchors, hollow concrete block walls are to be filled at the opening by minimum 3,500 PSI concrete.
- Steel mullions are not to be inside the ductwork. For ducted systems, each subdivided opening must be individually ducted.

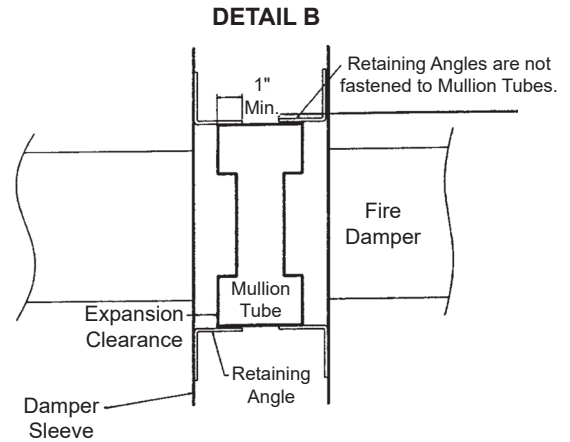

Reference the damper's installation instructions regarding the approved method of attaching the damper to the sleeve, attaching the retaining angles to the sleeve, required expansion clearances, sleeve gauge, etc.





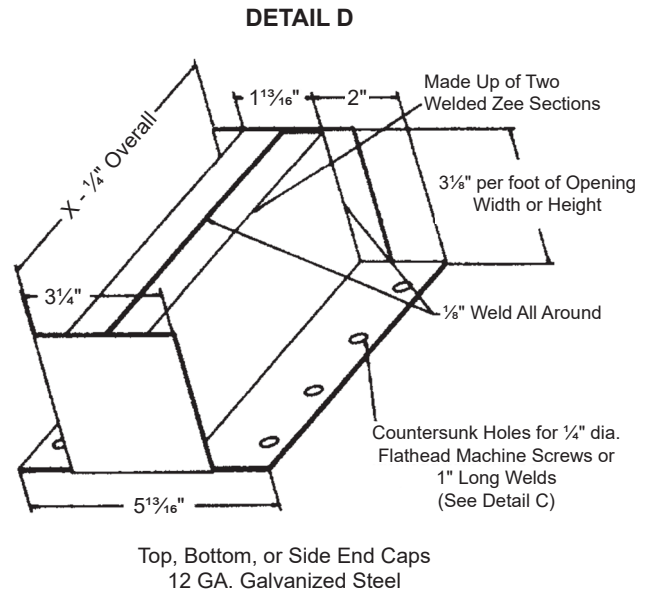
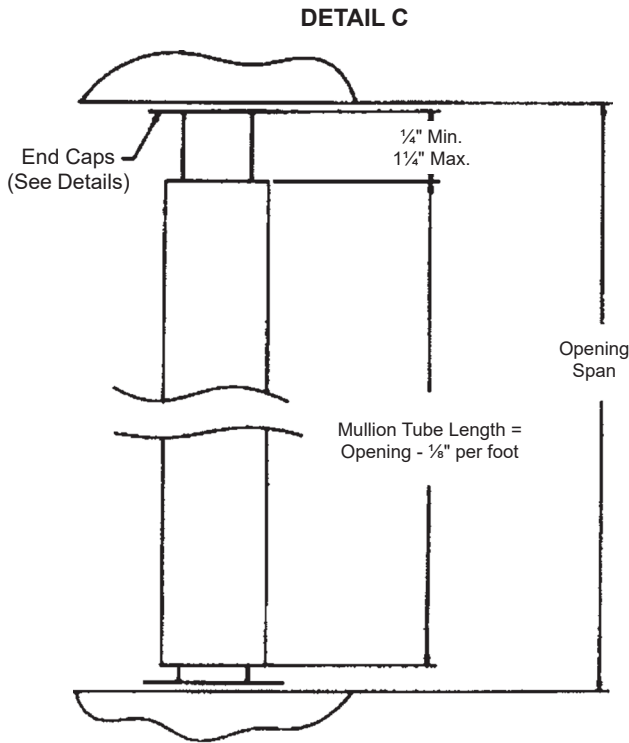

The end caps are attached by means of 1" long x 3/8" dia. steel expansion anchors embedded into the opening with 1/4" dia. flat head machine screws, eight per end cap. If a steel lintel is used, four 1" long welds per end cap (two per leg) may be used.

X = Wall Thickness

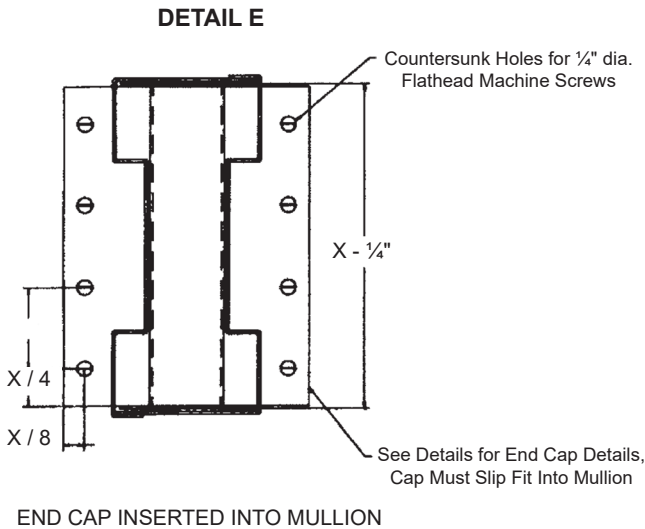

END CAP INSERTED INTO MULLION

All horizontal and vertical mullion tubes must be terminated with an end cap. These end caps may not be fastened to the mullion tube and must slide freely inside the mullion tube.

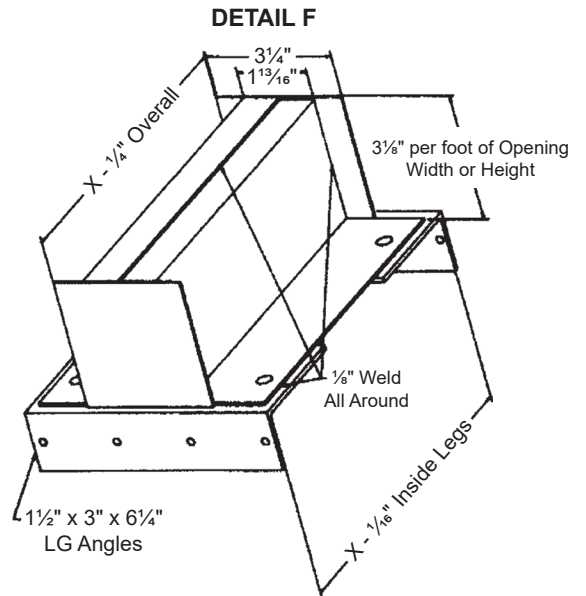

HORIZONTAL TO VERTICAL MULLION END CAP  
12 GA. GALVANIZED STEEL

Attach the horizontal mullion end caps to the vertical mullion tube by means of (12) 3/16" dia. blind rivets or by 1/8" full length weld.

